

Simple Mask ● created by dora cary



washable & reusable

fits most adults

difficulty: ● (easy)

orangedotquilts.com

The story behind the mask

Dr. Gary Goodman, the medical director of the Pediatric Intensive Care Unit at CHOC Children's Hospital in Mission Viejo, contacted me on March 18, 2020, with an urgent request for a better and easy-to-make handmade surgical mask design, what doctors call a "simple mask". I set to work immediately and came up with this simple, folded design that takes almost no time to make and fits most adults. The three layers of the mask protect well, and the mask is washable and reusable.

Fabric requirements (TIP: If your fabric is too bright or has a wild design, you can always use it with the wrong side out.)

1/3 yard quilting cotton - *this will make two masks*

OR

1 FQ (a Fat Quarter is 18" x 22") quilting cotton - *this will make one mask*

6" x 10" thin cotton batting - *I use Quilter's Dream 100% cotton batting in Select weight*

Round cord elastic: 2 mm diameter x 12"

Aluminum flat wire: 1/4" x 3" - *this is optional*

Cutting the fabric

From the quilting cotton cut:

- one 10" x 16 1/2" piece for the mask;
- two 1 3/4" x 3 1/2" pieces for the binding.

Cut the batting piece using the template on the last page.

Making the mask

All seam allowances are 1/4" unless otherwise mentioned.

STEP 1. Make a tube

Fold the quilting cotton piece in half, right side to right side, to 8 1/4" x 10". Sew along the opposite side to the fold to create a tube. Turn the tube right side out, press it flat and reinforce the seam by stitching it again on the outside. The finished size of your tube should be 8" x 10".

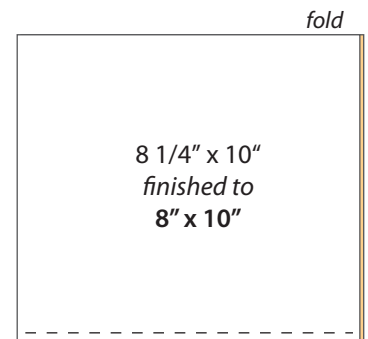

STEP 2. Make the shaping pocket

Insert the batting piece inside the tube, with the flat side against the fold. *The folded part of your tube will be the upper part of the mask. For reinforcement and a more customizable fit, a small piece of aluminum flat wire can be inserted in the shaping pocket, but even without the wire, the mask will work well.* Mark the middle of the fold and sew a centered 3" line, 3/8" away from the edge of the fold.

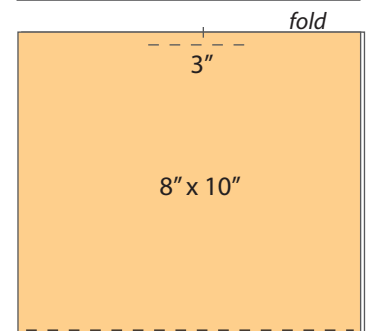

STEP 3. Mark the mask

Cut out the template on page 3 and use it to mark on your mask all the dots marked on the template, as well as the fold/crease lines. *I use a pencil to mark, it will wash out, and I poked my paper through at the first use, so all I have to do is lay the template on top of my fabric and mark all the dots through the holes then connect them.*

Making the mask *(continued)*

STEP 4. Cut the corners

With the mask template still on the fabric, mark all the corners and cut them away.

STEP 5. Sew the structure line/main fold

Fold the mask along the line marked "structure line/main fold", making sure all your marked dots remaining on the inside of the mask. Sew along this fold, as close to the edge as possible but making sure you catch all the layers. *This stitch line gives the mask structure and strength, it helps maintain the shape and not collapse. It also makes it easier to breath inside the mask and it keeps the mask from bunching in the mouth when you speak.*

STEP 6. Press the mask

Fold and press the diagonal lines at the top of the mask (above the main fold and on each side of the shaping pocket) and the two crease lines at the bottom of the mask **in the opposite direction of the main fold** and press the diagonal lines right below the main fold **in the same direction with the main fold**.

STEP 7. Fold the mask

Using the template as a guide, create the shape of the mask by folding the raw edges along the pressed lines and by bringing together to touch (*no social distancing for these dots ;)* dot A to dot A and then dot B to dot B on top of that. make sure all the lines line up to a straight line along the side edges. Pin in place and then sew a securing stitch along the edges.

At this point your mask should look like this. ... ▶



STEP 8. Attach the elastic and bind the raw edges

Cut the length of elastic in two equal pieces and pin each to the front of the mask, on each side of the raw sides. Place the binding strip on top and sew in place. *See the photo sequence below, left to right and top to bottom, for an illustration of the steps.* Repeat these steps for the other side.



TIP: When you sew the binding in place, keep the elastic away from the mask.



back of the mask



front of the mask

You have finished your mask! Now make another one and continue making as many as needed by your local hospitals. We're going to get through this together!

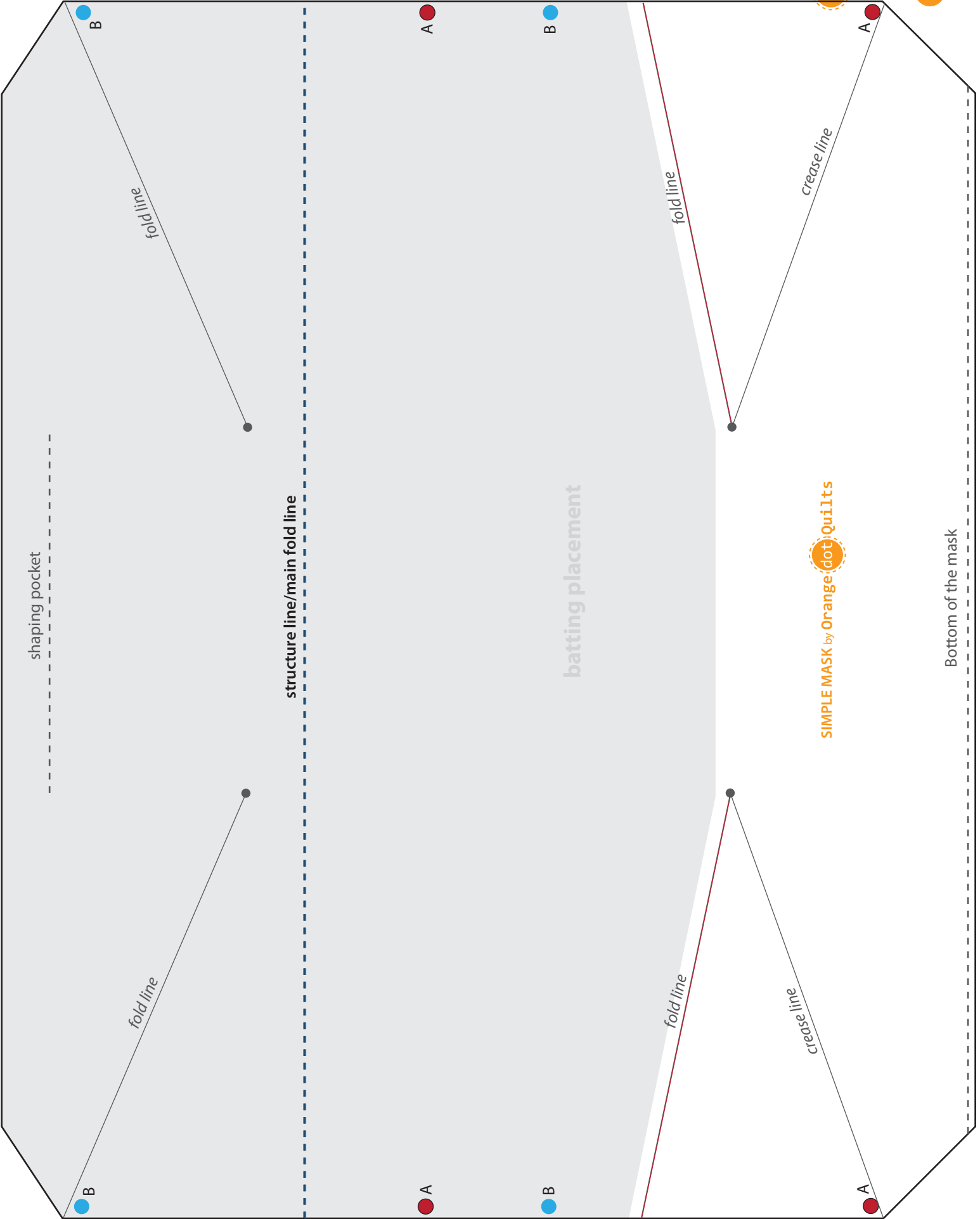

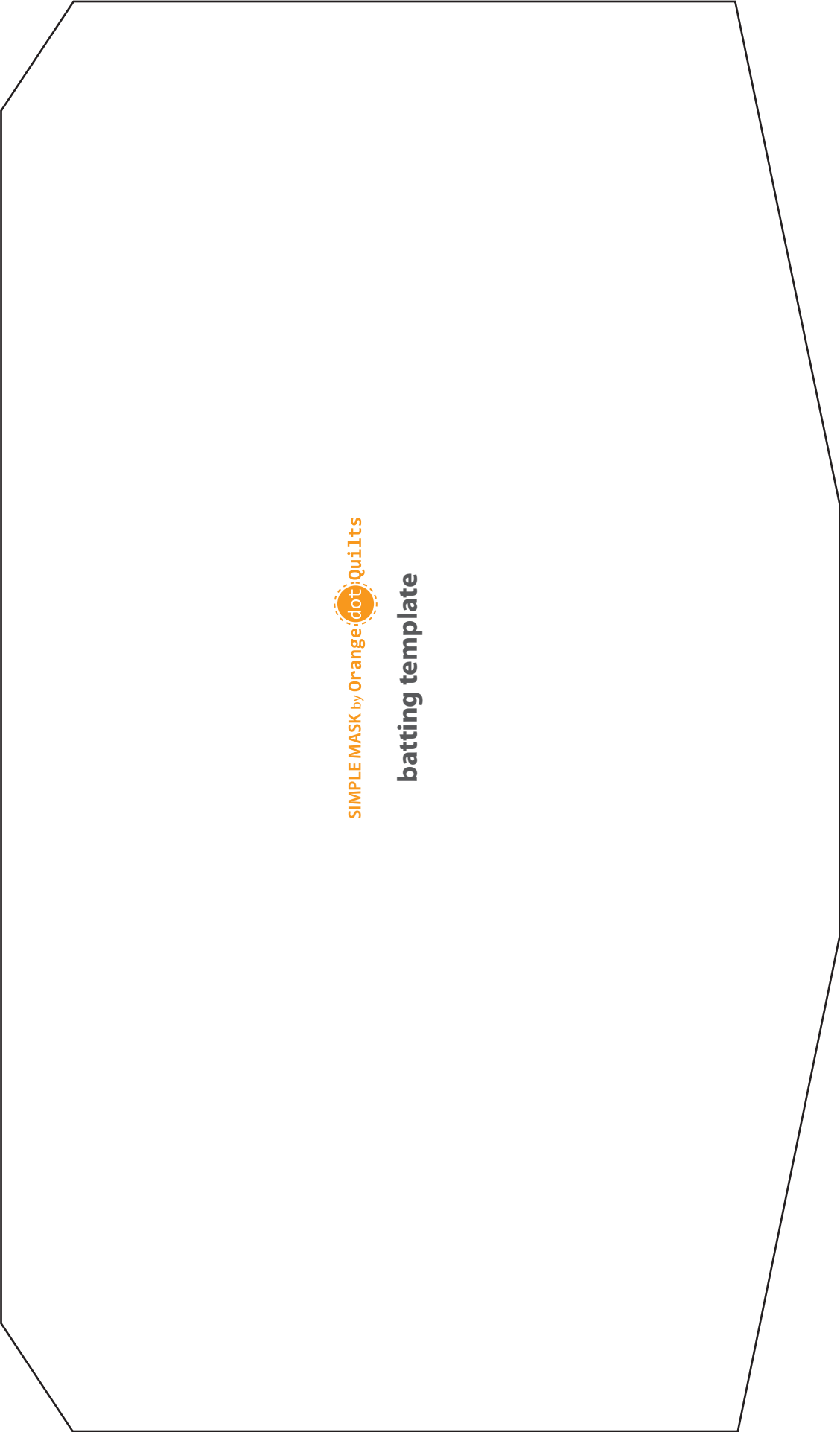

SIMPLE MASK by Orange dot Quilts

batting template

Orange dot Quilts

www.orangedotquilts.com orangedotquilts@gmail.com

Copyright 2020 Dora Cary

All images and artwork are property of the author and the author retains copyright after sale. All rights reserved.
The pattern can be copied and distributed if making masks for donations or personal/family/friends use ONLY.